

Susceptibility of Different Coliphage Genomes to Host-controlled Variation

ROSEMARY W. ESKRIDGE, HERBERT WEINFELD, AND KENNETH PAIGEN

Departments of Experimental Biology and Medicine C, Roswell Park Memorial Institute, New York
State Department of Health, Buffalo, New York

Received for publication 19 August 1966

Twenty-eight coliphages were studied for their susceptibility to four systems of host control variation in *Escherichia coli*. Both temperate and virulent phages were studied, including phages with ribonucleic acid, double- and single-stranded deoxyribonucleic acid (DNA) and glucosylated DNA. The systems examined were *E. coli* C-K, K-B, B-K, and K-K(P1). The C-K, K-B, and B-K systems affected temperate phages and nonlysogenizing mutants derived from temperate phages. In general, these systems did not restrict virulent phages. Phage 21e, a variant of phage 21, lost the ability to undergo restriction in the C-K and B-K systems, but retained susceptibility to the K-B and K-K(P1) systems. This suggests that the genetic site(s) on the phage, as well as in the host, determines susceptibility to host-controlled variation. Both temperate and dependent virulent phages were susceptible to the host control system resulting from the presence of prophage P1. The autonomous and small virulents were not susceptible. In a given system, the various susceptible phages differed widely in their efficiency of plating on the restricting host. If the few infections that occur arise in rare special cells, then different populations of special cells are available to different phage species. For most phage types, when a susceptible phage infected a nonrestricting host, the progeny showed the specificity appropriate to that host. Behavior of T3 was exceptional, however. When T3 obtained from *E. coli* K infected *E. coli* C or B, some of the progeny phages retained K host specificity, whereas others acquired the specificity of the new host.

The genome of a bacterial virus is subject to two kinds of variation: mutation and host-controlled variation. In contrast to the rare, stable heritable changes of mutation, the alteration in host-controlled variation may be applied simultaneously to almost all the members of a developing phage population, but is not hereditarily stable. For example, phage λ , after growth in *Escherichia coli* K-12, plates equally well on strains K and C, whereas λ propagated in strain C has a greatly reduced efficiency of plating (EOP) on strain K. The few successful infections occurring in strain K give rise to progeny which again plates equally well on both hosts. Thus, in contrast to mutation, host-controlled variation is, in general, determined only by the nature of the last host in which the phage was grown, and is independent of the prior history of the phage.

Since the original report of host-controlled variation of T-even phages by Luria and Human (22) and of the phages λ and P2 by Bertani and Weigle (8), numerous examples have been reported (4, 7, 19). Recently, it has been found that the phenomenon is not confined to viruses.

Restriction of both F particles and col-I in strains carrying prophage P1 was reported by Glover et al. (15). Arber and Morse (6) demonstrated that both zygotic induction and the formation of recombinants were decreased when crosses of Hfr K-12 \times F⁻ K-12(P1) were performed, as compared with crosses in which the Hfr parent carried the P1 prophage. Similar effects on recombination frequencies were obtained in crosses between *E. coli* K-12 and *E. coli* B by Boyer (9) and Pittard (25).

The restriction by *E. coli* B of T2 grown in B/4₀ has been shown (16, 27) to result from defective glucosylation of phage deoxyribonucleic acid (DNA). The behavior of λ in the host control systems involving *E. coli* K-12, K-12(P1), B, and C has been shown to be due to as yet undefined modifications of phage DNA during its synthesis in a given host (4, 5). In the case of λ , infectious DNA and intact phage show the same specificity in these systems (12).

Thus, host-controlled variation is a general phenomenon in which DNA may become modified when it is synthesized in one cytoplasm and

then undergo restriction upon entering another cytoplasm. We can therefore inquire as to whether nucleic acids which share a similar general structure are equally affected by host-controlled variation. To study this question, we examined the behavior of a selected set of bacteriophages.

In considering the results obtained, it should be borne in mind that *E. coli* populations contain rare special cells which are unable to restrict but which retain the ability to produce progeny phage with extended host range. These special cells are responsible for initiating the occasional plaques which form when P2 (8) and λ (3, 24, 28) particles with limited host range infect their restricting host. For phages not subjected to such an analysis, the EOP under the circumstance of restriction is also probably an estimate of the frequency of special cells in the host population, rather than a reflection of the intensity with which the majority of the population apply restriction.

MATERIALS AND METHODS

Nomenclature. A host control system consists of a pair of hosts in which phage produced by one member of the pair is restricted in its ability to multiply in the other member. Phages which plate equally well on both hosts show *extended host range*; phage particles which are restricted by one of the hosts are described as having *limited host range*. We have examined the pairs C-K, K-B, B-K, and K-K(P1). The first strain mentioned is that which produces phage with limited host range and is termed the *accepting host*. The second strain is the *restricting host* and produces phage with extended host range.

We have used the term *efficiency of plating* (EOP) in preference to "degree of restriction" to indicate the relative numbers of plaques formed when a limited phage is plated on both hosts. The former term carries no connotation suggesting the mechanism of restriction.

The origin of a lysate has been indicated according to Bertani and Weigle (8). Thus, λ .K indicates λ grown on *E. coli* K-12. This terminology has been used by other workers to indicate the host specificity of a given phage particle (4). In some cases, however, a host may produce phage particles with more than one host specificity (10, 19; see T3 below), and the properties of a single phage particle may differ from the average properties of a mass lysate. To avoid any ambiguity, we have used the conventional designation only in its operational sense to indicate the host in which the phage was grown. The symbols λ .C.K.C indicate a sequence of hosts, ending with the one in which the phage was most recently propagated.

Bacteria. The bacterial strains used are listed in Table 1. All are derivatives of *E. coli* C, B, or K. P1 lysogens were obtained by infecting the parent strain with Plkc in liquid culture at a multiplicity of infection of 0.1, aerating overnight, and selecting lysogenic clones. YS101 was used as a donor to transfer F particles to *E. coli* C and W3350.

Coliphages. The phages used and their sources are shown in Table 2. Except for ϕ X174 and S13, which grew only on *E. coli* C and its derivatives, all of the phages tested could grow on strains K and C or their F⁺ derivatives. All of the coliphages listed in the ATCC *Catalog of Cultures* (6th ed.) which gave plaques on both C and K were included. Our original stocks of 434 and 82 did not give plaques on strain C, but host range mutants of these phages were obtained which had acquired this ability.

TABLE 1. Source and designation of bacteriophage and *Escherichia coli* strains employed

Strain	Donor or derivation	Designation
<i>E. coli</i>		
C	J. J. Weigle	W53
C(P1kc)	This laboratory ^a	C(P1); Q117
CF ⁺	This laboratory ^b	Q162
K-12	J. J. Weigle	W3350
K-12(P1kc)	This laboratory ^a	W3350(P1kc); K(P1); Q94
K-12 F ⁺	This laboratory ^b	W3350 F ⁺ ; Q163
B	W. Arber	Bc251
HfrH	A. Campbell	Q81
HfrH(Plkc)	This laboratory ^a	Q119
Sources of phages and F ⁺		
W3350(λ)	J. J. Weigle	W12
C600(434)	J. J. Weigle	W22
C600(82)	J. J. Weigle	W37
C600(21)	A. D. Kaiser	B99
C600(P1kc)	S. Lederberg	141
K-12 F ⁺	N. Franklin	YS 101

^a Plkc used for the construction of these strains was derived from C600(P1kc).

^b Strains infected with F⁺ from YS 101.

TABLE 2. *Coliphages examined for host-controlled modification*

Class	Phage	Source
Temperate, double-stranded DNA	λ	UV induction of W3350(λ)
	λ b2	J. J. Weigle
	λ ch	λ c \times λ h: J. J. Weigle
	λ vir h	J. J. Weigle
	λ i ⁴⁸⁴	A. D. Kaiser and J. J. Weigle
	λ i ⁸²	J. Adler
	434	UV induction of prophage in W22
	82	UV induction of prophage in W37
	21	UV induction of prophage in B99
	21e	Variant derived from 21
	P1kc	UV induction of prophage in 141
	P2	A. Campbell
ϕ 80	N. Franklin	
Virulent, double-stranded DNA	T1, T2, T6	A. Campbell
	T3, T4, T4rII, T5	A. D. Hershey
	T3, T7	C. Fuerst
	C36	ATCC 8677B
	Strain 5	ATCC 12141B
	53 α	ATCC 12143B ₄
	Fcz	ATCC 12142B ₅
	Go	Primary isolate from raw sewage
Virulent, single-stranded DNA	ϕ X174, S13	I. Tessman
	f1	N. Zinder
Virulent, single-stranded RNA	f2, f4, R17	N. Zinder
	MS2	A. Campbell

Each phage was cloned by single plaque isolation, and a donor lysate was made from the resuspended plaque by the confluent plate method, with *E. coli* K W3350 as host whenever possible. To confirm the identity of the phages, each lysate was tested for its ability to form plaques on a set of some 20 *E. coli* strains chosen for their ability to discriminate between phages. No two phages showed identical behavior. Host ranges, plaque morphologies, and requirements for calcium ions were as described in the literature.

Media. Plaques were picked and individually suspended in dilution medium [0.01 M MgSO₄, containing 0.006% gelatin, buffered with 0.01 M tris(hydroxymethyl)aminomethane chloride (pH 7.2 to 7.4)]; dilutions were made in the same medium. Fresh overnight cultures of the standard hosts, grown in tryptone broth (1% Bacto Tryptone, 0.5% NaCl; pH 7.2) at 37 C with aeration, were used for phage titrations. Most phages were titrated on tryptone-agar (1% Bacto Tryptone, 0.5% NaCl, 1% agar); the top agar was of similar composition, but with 0.65% agar. For phages P1, P2, MS2, R17, f1, f2, and f4, yeast extract (0.5%), glucose (0.12%), and CaCl₂ (2.5 \times 10⁻³ M) were added to the tryptone-agar, and the top agar contained 0.8% nutrient broth powder, 0.5% NaCl, and 0.65% agar (21). For phages ϕ X174 and S13, tryptone-agar was supplemented with 1.2% glucose. Plaque-forming units were assayed according

to the method of Adams (1) or by the drop dilution method described below.

Experimental design. A standard procedure to screen the phages was established. For the *E. coli* K-*E. coli* B system the donor lysates, ϕ .K, were tested directly by titering on the two strains. For the B-K system, ϕ .B, obtained from plaques on B, was similarly tested. For the other two systems, the donor lysate was plated on the three hosts, *E. coli* C, *E. coli* K, and *E. coli* K(P1). The phage present in individual plaques picked from each host was then titered on each of the three hosts. For this purpose, 0.01-ml samples of each of five serial 10-fold dilutions of the resuspended phage were spotted on three plates, each seeded with one of the three hosts. Figure 1 shows a representative set of results for phage λ ch. This procedure yielded the following information: (i) whether a phage grown in C was restricted in K; (ii) whether a phage grown in K was restricted in K(P1); (iii) an estimate of the EOP on the restricting host; and (iv) a distinction between host-controlled variation and host range mutation. This is obtained by showing the acquisition of limited host range of the phage progeny only after passage through the accepting host.

For the C-K system, it is sufficient to compare the EOP of ϕ .K.C and ϕ .K.K on *E. coli* K in order to distinguish between host-controlled variation and host range mutation. For the K-K(P1) system, it was also necessary to obtain phage from the bottom row of the

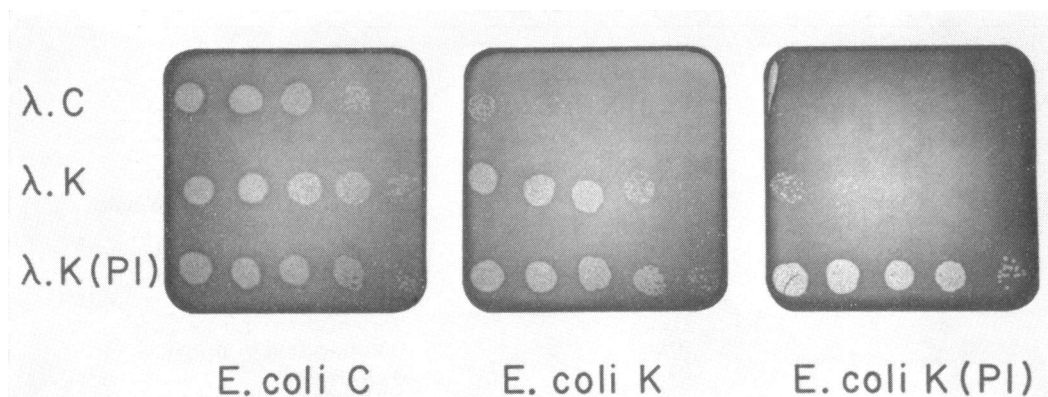

FIG. 1. Drop dilution assay. A suspension of phage from a single plaque was serially diluted by 10-fold steps; 0.01 ml of each dilution was placed on a plate previously seeded with the required host. For a given horizontal row starting from the left, each successive spot represents a more dilute phage suspension. The figure shows that $\lambda.C$ is restricted in strains K and K(P1), that $\lambda.K$ is restricted only in strain K(P1), and that $\lambda.K(P1)$ plates equally well on all three hosts.

K plate used in the screen (Fig. 1). This phage was $\phi.K.K(P1).K$ and was demonstrated to have limited host range by titring on K and K(P1). In the case of phages susceptible to both B-K and K-B restriction, no such test was possible owing to the reciprocity of the systems.

Phages were tested simultaneously in two of our laboratories, and for each phage at least three plaques from each host were examined by the spot method. More accurate estimates of the EOP were obtained by the pour-plate method. This gave values for the EOP on the restricting host which were similar to, but usually slightly higher than, the values obtained by the spotting technique.

RESULTS

C-K system. The susceptibility to restriction by *E. coli* K of phages grown on *E. coli* C is shown in Fig. 2A. A group of phages did not show restriction. This included all of the virulent phages and the single temperate phage, P1kc. All other temperate phages were restricted to various extents. We therefore conclude that not all nucleic acid base sequences are susceptible to the same host control system, since no ribonucleic acid (RNA) and only some DNA phages were affected. The plaques arising after infection of *E. coli* K by $\lambda.C$ are due to the presence in the K population of special cells incapable of restricting $\lambda.C$. If this is also the case for other phages, then the number of special cells available to each phage type varies considerably.

The segregation of the phages into two groups and the various EOP values observed for the temperate phages permit the additional conclusion that, in the C-K system, susceptibility to host-controlled variation is a hereditary property

of the phage DNA. This implies that susceptibility to host-controlled variation should be amenable to genetic variation and selection. This was confirmed in the case of phage 21 when a variant, 21e, which had lost susceptibility, was obtained. The variant arose by either mutation or recombination with the host genome during a series of infective cycles of growth on W3350 under ostensibly nonselective conditions.

The difference between temperate and virulent phages cannot be due either to the ability to lysogenize or to sensitivity to a phage immunity system. The mutants λb_2 , $\lambda clear$, and λvir were all restricted to the same degree as their parent. These three mutants are unable to lysogenize, and λvir is insensitive to the phage immunity system. Exchange of the entire immunity region also did not affect the ability of λ to be restricted. The EOP was the same when the phage carried the chromosome arms of λ and the immunity region of λ , 82 (2), or 434 (18), although the three prototype phages themselves were restricted to a very different extent. In the case of the hybrid between λ and 82, the whole right arm of the phage, including the immunity region, was derived from 82. Thus, the genetic locus determining EOP does not reside in this region.

Special case of T3. We have not observed restriction in *E. coli* K of phage T3.C in a lysate produced in liquid culture. However, clones of T3.C, obtained from isolated plaques of T3.K plated on strain C, became susceptible to restriction in K. Each clone of T3.C was associated with a characteristic EOP, ranging from 1 to 10^{-4} (Table 3).

These observations suggest that a given T3.C

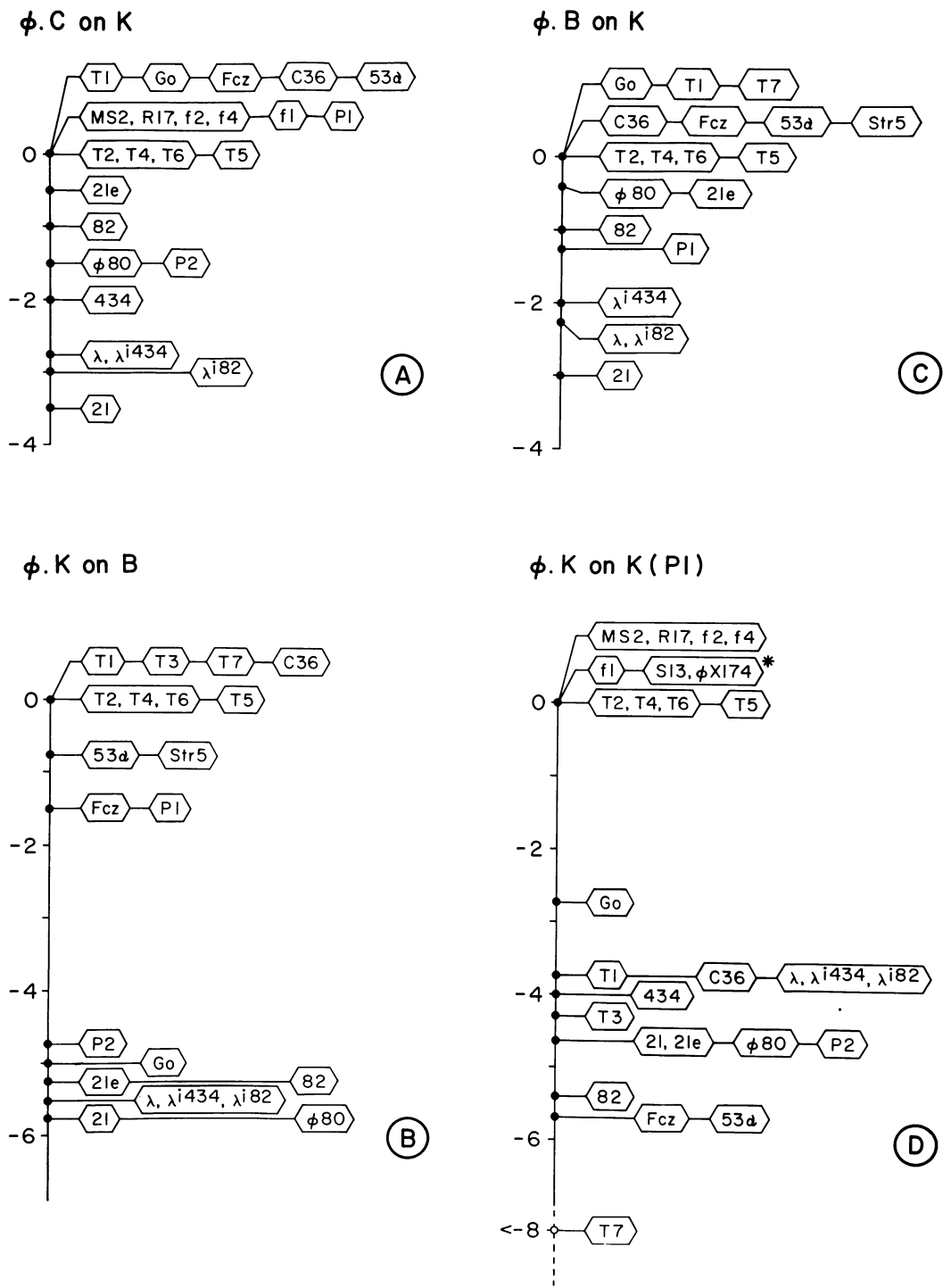

FIG. 2. Host control system. The vertical axis represents the logarithm of the efficiency of plating on the restricting host when compared with that on the accepting host. For 2A and 2D, the phage from a single plaque was used. For 2B and 2C, lysates were used in most experiments, although clones from single plaques were tested for some phages. Each set of data was obtained by titrating all phage types on a single pair of cultures and is representative of several such experiments. F^- strains were used except for phages MS2, R17, f2, f4, and f1, which were titered on the corresponding F^+ strains. Phage 434 is not included in data involving strain B, as no mutant capable of plating on this strain was found. For S13 and $\phi X174$ (asterisk), the host pair consisted of C and C(PI), because these phages do not infect strain K. The restriction and modification properties associated with prophage PI are expressed in *E. coli* C as well as in *E. coli* K.

TABLE 3. Behavior of T3.C plaques in the C-K system^a

Plaque no.	(Titer on K)/(titer on C)			
	T3F.C		T3H.C	
	Original EOP	EOP after 5 months ^b	Original EOP	EOP after 5 months ^b
1	1.3×10^{-1}	$<10^{-4}$	5×10^{-3}	$<5 \times 10^{-4}$
2	1		1.3×10^{-3}	$<5 \times 10^{-4}$
3	3×10^{-2}		3×10^{-1}	
4	5×10^{-1}		3×10^{-2}	
5	1		1	
6	1.5×10^{-2}		1	
7	5×10^{-1}		7×10^{-2}	
8	3×10^{-2}		2×10^{-1}	
9	10^{-3}		10^{-1}	
10	10^{-1}			
11	5×10^{-2}			
12	10^{-1}			

^a T3F (T3 from C. Fuerst) and T3H (T3 from A. D. Hershey) were cloned on *E. coli* C. The plaques were picked and their phage titers determined on strains K and C. By titration on C, each plaque contained 10^8 to 10^9 phages. EOP values on K varied initially from 1 to 10^{-3} . When log-phase K cells were used, the EOP was decreased by a factor of 10^2 over the values reported.

^b Phage titers were too low to determine actual values.

plaque has two populations of phages, one group carrying C specificity, the other retaining K specificity. The EOP exhibited by the phages in a given plaque will therefore depend on the ratio of these two populations, which apparently varies from plaque to plaque. The lowest EOP obtained, $<10^{-4}$, would then represent an upper limit for the actual EOP of T3 phages with C specificity. Further evidence for the existence of two subpopulations of T3.C was the finding (Table 3) that T3 particles able to plate on K cells are less stable than the bulk of the population.

Two other phages gave indications of similar behavior, but to a lesser extent than T3. For phage T7.C, the phages in only 2 of 14 plaques tested were restricted in K; for Str.5.C, only 1 of 14 plaques contained phages showing measurable restriction.

B-K and K-B systems. The behavior of phages in the B-K system (Fig. 2C) was similar to that in the C-K system (Fig. 2A). [The efficiency of plating of λ .B on K shown here is much higher than the value, 4×10^{-4} , reported by Arber and Dussoix (4). We find that this is due to the use of strain W3350, a K-12 strain which restricts less strongly than the strain (C600) used by these authors.]

The distribution of phages along the vertical axis is remarkably similar in these two figures. This suggests that the modification of the DNA of any one phage that is detected by strain K is the same whether it is applied by strain B or strain C.

Temperate phages grown in *E. coli* K were restricted in *E. coli* B (Fig. 2B). Most of the virulent phages were not restricted. Although the virulent phages, 53 α , Strain 5, and Fcz showed a decrease in EOP on B, it was quite small. The temperate phage P1kc behaved similarly to this subgroup of virulent phages. The major exception among the virulent phages was Go, which was not susceptible.

The phages 21e and Go were both susceptible to restriction in B, but not in K. Thus, if a phage is susceptible to one host control system, it is not necessarily susceptible to another closely related system. This suggests that separate structural features of the phage are required for each of these systems of host-controlled variation.

The suggestion, that the modification of DNA that is detected by strain K is the same whether this feature is applied by strain B or strain C, is in agreement with the results of Lederberg (20) which indicate that only two host control systems operate between strains C, K, and B. Lederberg's data show that when strain K loses its ability to restrict λ .C it also loses its ability to restrict λ .B, whether the loss is caused by heating the K cells or by mutation. Similar results were obtained with strain B in its ability to restrict λ .C and λ .K. Other authors have confirmed the effect of mutation (9, 11, 30, 31). Thus, the same mechanism participates in the restriction of both ϕ .C and ϕ .B by strain K, and another mechanism ensures the restriction of ϕ .C and ϕ .K by strain B.

The data presented here provide a completely independent confirmation of this interpretation. Phage 21 is restricted in K after growth in either C or B. The mutant of this phage, 21e, is no longer restricted in K after growth in either of these hosts. However, 21e, like 21, is restricted in B after it has been grown in either C (*unpublished data*) or K. The simultaneous loss of ability to restrict ϕ .C and ϕ .B after mutation of a K host suggested that a common host element is required in both cases (20). Similarly, the simultaneous loss of ϕ .B and ϕ .C restriction upon phage mutation suggests that a common phage element was sensitive in both cases.

K-K(P1) system. Restriction of phage multiplication in *E. coli* K(P1) is illustrated in Fig. 2D. In contrast to the other systems, conventional virulent phages, as well as the temperate phages, were subject to restriction. The only phages not susceptible to restriction were the RNA phages,

those with single-stranded DNA, those with glucosylated DNA, and T5.

The wide range of values for EOP observed among the various phages again suggests the possibility of several populations of special cells. Indeed, for T7 there appear to be no special cells. T7 adsorbed to K(P1) and killed the cells, but no plaques were observed.

The reduced EOP of susceptible phages on P1 lysogens depends upon not only the host from which the phage was obtained, but also the specific cell pair used for testing. Figure 3 shows the results obtained when the temperate phage 82, and the virulent phage Go, were grown on two hosts, HfrH (a K-12 strain) and C, and then titered on three cell pairs: HfrH-HfrH(P1), K-K(P1), and C-C(P1). When either phage was grown in HfrH, there was very little variation in its relative EOP on these cell pairs, but considerable variation was observed when the phage was grown in C. Several other phages have been examined in this way, and a similar degree of variability was observed.

The behavior of T3 in the K-K(P1) system was remarkable. T3.K, when plated on K(P1), gave very tiny plaques, as reported by Lederberg (19). These plaques contained phages indistinguishable from T3.K. Furthermore, the total number of phages per plaque, as determined by their titer on K, was approximately equal to the number of phages found in plaques made by T3.K on C or K. These results can be explained by assuming, first, the production of only T3.K in a special cell population K(P1) during the first cycle of

growth on the plates, and, second, the breakdown of host restriction under the growth conditions prevailing during continued incubation. Glover et al. (15) observed cell death, but no plaque formation, when T3 was plated on K(P1). We observed killing and no plaques under only one set of conditions, namely, after T3.K was plated on HfrH(P1). When the same lysate of T3.K was plated on K(P1) or C(P1), or when T3.HfrH was plated on the same three lysogens, the characteristic small plaques were observed. It appears that both the cell in which T3 is grown and the cell in which it is tested contribute toward determining whether plaque formation or killing occurs.

DISCUSSION

The results have been reported in terms of the susceptibility of a set of coliphages to four host control systems. The phages in the set were originally selected according to the kind of nucleic acid they contain. They may also be analyzed in terms of other properties, such as size and virulence. Thus, four subsets of phages can be distinguished: temperate, dependent virulent, autonomous virulent, and a set including RNA and single-stranded DNA phages which we call the small virulent phages. The terms "autonomous virulent" and "dependent virulent" are used here in the sense of Whitfield (29) to distinguish the T-even phages and T5 from other double-stranded virulent phages. In the four cell pairs examined here, temperate phages were more consistently susceptible to restriction than were the virulent phages. The dependent virulent phages were susceptible only to the restriction imposed by prophage P1, whereas the autonomous and small virulent phages were not susceptible to restriction in any system in which they were tested.

Temperate phages. The susceptibility of temperate phages to restriction appears not to be due to any of the functions normally associated with the ability to lysogenize, or to sensitivity to phage phage immunity systems. There must, therefore, be some other feature associated with the structure or functions of the chromosomes of temperate phages which is responsible for these effects, and which is lacking in the virulent phages. A similar feature is probably also associated with the *E. coli* chromosome itself, as cellular DNA can become susceptible to restriction (6, 9, 25).

In both the C-K and B-K systems, temperate phages differed from each other in their EOP on the restricting host. The value we have given for phage $\phi 80.C$ was that found for the most strongly restricted clone. Other clones of $\phi 80.C$ underwent very little restriction, in confirmation of the result reported by Matsushiro (23). The restric-

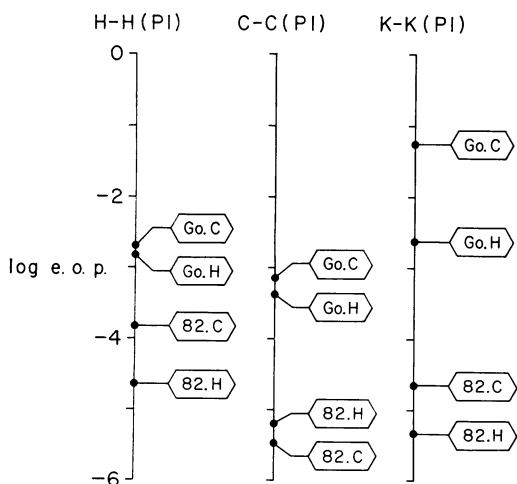

FIG. 3. Variability in P1 restriction. Phages 82 and Go were grown on strains C and HfrH. They were titered on three pairs of strains: HfrH and HfrH(P1), C and C(P1), K and K(P1).

tion of phages 82 and 21e also was very slight. In contrast to this, these three phages were severely restricted in the K-B and K-K(P1) systems. It appears that control of susceptibility to the latter two systems is quite different from that for C-K and B-K.

Pl_{kc} was not susceptible to restriction in the C-K system, and only slightly so in B-K and K-B. Phage P1, however, is very different from the other temperate phages. It performs generalized transduction, has no mappable prophage site, and does not undergo zygotic induction. Its lack of susceptibility to restriction may be related to these properties.

Dependent virulent phages. The dependent virulent phages, in general, were susceptible only in the K-K(P1) system. In this case, the EOP was quite low and, except for T3 and T7, these phages behaved like the temperate phages.

The behavior of T3 in K(P1), and the T-even phages in *Shigella*(P2) (19), is formally similar to the behavior of the T-even rII mutants infecting strains lysogenic for λ . In all cases, infection is lethal to the cell, even when no progeny phage are produced, and the few progeny which do arise have properties identical to those of the parental phage. There appears to be a correlation in these cases between killing during abortive infection and the failure to produce phage with new specificity.

The behavior of T3 was also unusual in the C-K system, in which phages with both limited and extended host ranges were found in the same plaque. We do not yet know whether a single C cell can yield both types of phage, as has been shown for phage T1 in *E. coli* B(P1) (10). The ratio of the two types varied from plaque to plaque. This variation within plaques and between plaques is reminiscent of the results obtained by Fraser (13) when she examined the behavior of T3 and its host range mutants on B and several independent B/3 strains. A similar system was used by Fukumi and Nojima (14), who interpreted their results in terms of host-controlled variation rather than host range mutation. Unfortunately, in neither case are data available to show whether the transition from limited to extended host range was reversible. The restriction of T3 reported by Schell et al. (26) was associated with the presence of an F particle and seems to be unrelated to the observations described here.

Autonomous and small virulent phages. Neither the autonomous virulent nor the small virulent phages were susceptible to restriction in the systems tested. Absence of restriction of MS2 in the K-K(P1) system has already been reported by Horiuchi and Adelberg (17). Host-controlled

variation of the T-even phages arises as a consequence of nonglycosylation of the phage DNA (16, 27). Restriction, but not modification, of the autonomous virulent phages was also reported by Lederberg (19) in *Shigella* lysogenized by P2.

Lack of susceptibility of a phage to a given system could be due to one of two possibilities. First, the phage nucleic acid may not acquire that structural feature which results in restriction of other phages. Alternatively, the restricting host may accept a phage whose nucleic acid carried the structural feature normally responsible for restriction if, as a consequence of some other property of the phage, the host was unable to recognize this feature on the phage DNA.

Special cells. The basis for the non-zero EOP typically seen on the restricting host is not always clear. For T3.C infecting K cells, it is probably due to a mixture of phages types with limited and extended host ranges. For λ .C in K, λ .K in K(P1), and P2.*Shigella* in *E. coli* B, it is due to the presence in the restricting population of rare special cells which have lost the ability to restrict (8, 24). In a special K cell, a single λ .C particle suffices to initiate phage multiplication. For the majority of K cells, which possess the ability to restrict, the possibility of a successful infection by λ .C is markedly dependent upon the multiplicity of infection (24). Even here, the response of an individual K cell appears to be an all-or-none affair; in the event that the restriction barrier is overcome, all phages entering a restricting cell multiply equally (28). Thus, there appear to be only two types of cells: the majority of the population, which restricts, and the minority, which does not. There is no suggestion that the EOP reflects a variation in intensity of restriction from cell to cell in the majority population.

Our data show that, in many cases, two susceptible phage species exhibit different EOP values when restricted by the same host. In the absence of any evidence of variable restriction, it appears safer to consider that these differences arise from the availability of several populations of special cells in a single culture. For example, the number of special K cells available to ϕ 80.C and P2.C would be 100-fold greater than the number of special cells available to 21.C. This raises the question of whether the special cell population for the phage with lower efficiency is a subpopulation of the cells capable of plating the other phage, or whether it is an independent, randomly overlapping population.

General. Several kinds of specificity exist in the expression of host-controlled variation. A given cell pair may exert an effect on only certain kinds of phages or nucleotide sequences. A phage which

exhibits host-controlled variation in one cell pair is not necessarily subject to it in another. Additionally, some phages were completely unsusceptible to host-controlled variation in the four systems examined.

Some of these results were anticipated by the observations of Lederberg (19) that the T-even and T5 but not the other T phages are restricted in *Shigella*(P2), and that the reverse is true in B(P1) and *Shigella*(P1). It seems clear that each host control system must be considered to be specific in terms of the DNA sequences subject to it.

As final evidence for the participation of specific DNA sequences in the phenomenon of host-controlled variation, we have found a phage mutant (21e) which has escaped susceptibility to restriction. Moreover, a change in the genetic structure of DNA which alters its susceptibility to one system does not necessarily affect its behavior toward another.

ACKNOWLEDGMENTS

The technical assistance of Kathleen F. Carr is gratefully acknowledged.

This investigation was supported by Public Health Service grant AI-03027 from the National Institute of Allergy and Infectious Diseases, and by grant GB-4637 from the National Science Foundation.

LITERATURE CITED

- ADAMS, M. H. 1950. Methods of study of bacterial viruses. *Methods Med. Res.* 2:1-73.
- ADLER, J., AND A. D. KAISER. 1963. Mapping of the galactose genes of *Escherichia coli* by transduction with phage P1. *Virology* 19:117-126.
- ARBER, W. 1964. Host specificity of DNA produced by *Escherichia coli*. III. Effects on transduction mediated by λ dg. *Virology* 23:173-182.
- ARBER, W., AND D. DUSSOIX. 1962. Host specificity of DNA produced by *Escherichia coli*. I. Host-controlled modification of bacteriophage λ . *J. Mol. Biol.* 5:18-36.
- ARBER, W., S. HATTMAN, AND D. DUSSOIX. 1963. On the host-controlled modification of bacteriophage λ . *Virology* 21:30-35.
- ARBER, W., AND M. L. MORSE. 1965. Host specificity of DNA produced by *Escherichia coli*. VI. Effects on bacterial conjugation. *Genetics* 51:137-148.
- BERTANI, G. 1953. Infections bactériophagiques secondaires des bactéries lysogènes. *Ann. Inst. Pasteur* 84:273-280.
- BERTANI, G., AND J. J. WEIGLE. 1953. Host controlled variation in bacterial viruses. *J. Bacteriol.* 65:113-121.
- BOYER, H. 1964. Genetic control of restriction and modification in *Escherichia coli*. *J. Bacteriol.* 88:1652-1660.
- CHRISTENSEN, J. R. 1961. On the process of host-controlled modification of bacteriophage. *Virology* 13:40-43.
- COLSON, C., S. W. GLOVER, N. SYMONDS, AND K. A. STACEY. 1965. The location of the genes for host-controlled modification and restriction in *Escherichia coli* K-12. *Genetics* 52:1043-1050.
- DUSSOIX, D., AND W. ARBER. 1965. Host specificity of DNA produced by *Escherichia coli*. IV. Host specificity of infectious DNA from bacteriophage lambda. *J. Mol. Biol.* 11:238-246.
- FRASER, D. K. 1957. Host range mutants and semitemperate mutants of bacteriophage T3. *Virology* 3:527-553.
- FUKUMI, H., AND T. NOJIMA. 1954. An essential feature of host range mutation. Third report of host-controlled variation. *Japan. J. Med. Sci. Biol.* 7:585-614.
- GLOVER, S. W., J. SCHELL, N. SYMONDS, AND K. A. STACEY. 1963. On the host-induced modification by phage P1. *Genet. Res.* 4:480-482.
- HATTMAN, S., AND T. FUKASAWA. 1963. Host-induced modification of T-even phages due to defective glucosylation of their DNA. *Proc. Natl. Acad. Sci. U.S.A.* 50:297-300.
- HORIUCHI, K., AND E. A. ADELBERG. 1965. Growth of male-specific bacteriophage in *Proteus mirabilis* harboring F-genotes derived from *Escherichia coli*. *J. Bacteriol.* 89:1231-1236.
- KAISER, A. D., AND F. JACOB. 1957. Recombination between related temperate bacteriophages and the genetic control of immunity and prophage localization. *Virology* 4:509-521.
- LEDERBERG, S. 1957. Suppression of the multiplication of heterologous bacteriophages in lysogenic bacteria. *Virology* 3:496-513.
- LEDERBERG, S. 1965. Host-controlled restriction and modification of deoxyribonucleic acid in *Escherichia coli*. *Virology* 27:378-387.
- LENNOX, E. S. 1955. Transduction of linked genetic characters of the host by bacteriophage P1. *Virology* 1:190-206.
- LURIA, S. E., AND M. L. HUMAN. 1952. A non-hereditary, host-induced variation of bacterial viruses. *J. Bacteriol.* 64:557-569.
- MATSUSHIRO, A. 1963. Specialized transduction of tryptophan markers in *Escherichia coli* K12 by bacteriophage ϕ 80. *Virology* 19:475-482.
- PAIGEN, K., AND H. WEINFELD. 1963. Cooperative infection by host-modified lambda phage. *Virology* 19:565-572.
- PITTARD, J. 1964. Effect of phage-controlled restriction on genetic linkage in bacterial crosses. *J. Bacteriol.* 87:1256-1257.
- SCHELL, J., S. W. GLOVER, K. A. STACEY, P. M. A. BRODA, AND N. SYMONDS. 1963. The restriction of phage T3 by certain strains of *Escherichia coli*. *Genet. Res.* 4:483-484.
- SHEDLOVSKY, A., AND S. BRENNER. 1963. A chemical basis for the host-induced modification of T-even bacteriophages. *Proc. Natl. Acad. Sci. U.S.A.* 50:300-305.
- WEINFELD, H., AND K. PAIGEN. 1964. Evidence

- for a new intermediate state of the viral chromosome during cooperative infection by host-modified lambda. *Virology* **24**:71-83.
29. WHITFIELD, J. F. 1962. Lysogeny. *Brit. Med. Bull.* **18**:56-63.
30. WOOD, W. B. 1965. Mutations in *E. coli* affecting the host-controlled modification of bacteriophage λ . *Pathol. Microbiol.* **28**:73-76.
31. WOOD, W. B. 1966. Host specificity of DNA produced by *Escherichia coli*: bacterial mutations affecting the restriction and modification of DNA. *J. Mol. Biol.* **16**:118-133.